

Stainless Steel Knurled Head Nuts

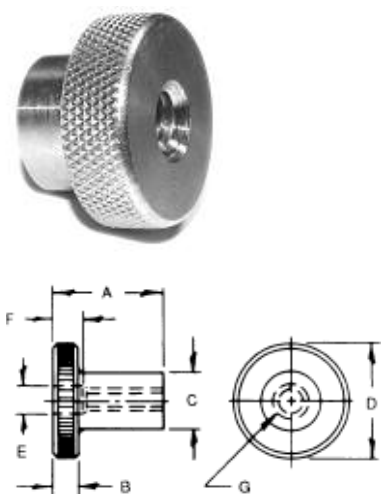

- Machined from 303 stainless steel
- Diamond knurl
- Full interior thread

PART #	Thread						
	G	A	B	C	D	E	F
8500	#4-40	3/8	1/8	1/4	1/2	1/8	1/8
8501	#4-40	5/8	1/8	1/4	1/2	1/8	3/8
8502	#4-40	3/8	1/8	1/4	3/4	1/8	1/8
8503	#4-40	5/8	1/8	1/4	3/4	1/8	3/8
8504	#6-32	3/8	1/8	1/4	1/2	#26 (.147)	3/32
8505	#6-32	5/8	1/8	1/4	1/2	#26 (.147)	11/32
8506	#6-32	3/8	1/8	1/4	3/4	#26 (.147)	3/32
8507	#6-32	5/8	1/8	1/4	3/4	#26 (.147)	11/32
8508	#8-32	3/8	1/8	5/16	1/2	#15 (.180)	1/4
8509	#8-32	5/8	1/8	5/16	1/2	#15 (.180)	1/4
8510	#8-32	3/8	1/8	5/16	3/4	#15 (.180)	1/4
8511	#8-32	5/8	1/8	5/16	3/4	#15 (.180)	1/4
8512	#10-24	7/16	3/16	3/8	1/2	13/64	1/4
8513	#10-24	11/16	3/16	3/8	1/2	13/64	1/4
8514	#10-24	7/16	3/16	3/8	1	13/64	1/4
8515	#10-24	11/16	3/16	3/8	1	13/64	1/4
8516	#10-32	7/16	3/16	3/8	1/2	13/64	1/4
8517	#10-32	11/16	3/16	3/8	1/2	13/64	1/4
8518	#10-32	7/16	3/16	3/8	1	13/64	1/4
8519	#10-32	11/16	3/16	3/8	1	13/64	1/4
8520	1/4-20	1/2	1/4	1/2	3/4	17/64	1/4
8521	1/4-20	3/4	1/4	1/2	3/4	17/64	1/4
8522	1/4-20	1/2	1/4	1/2	1	17/64	1/4
8523	1/4-20	3/4	1/4	1/2	1	17/64	1/2
8524	1/4-20	1	1/4	1/2	1	17/64	1/2

Stainless Steel Knurled Equalizing Nuts

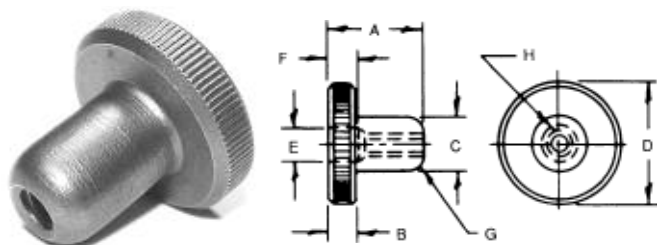

- Machined from 303 stainless steel
- Straight knurl

PART #	Thread							
	H	A	B	C	D	E	F	G
3501	#4-40	5/8	1/8	9/32	1/2	1/8	1/4	3/32
3502	#6-32	5/8	1/8	9/32	1/2	#26 (.147)	1/4	3/32
3503	#8-32	5/8	1/8	5/16	1/2	#15 (.180)	1/4	3/32
3750	#10-24	3/4	3/16	3/8	3/4	13/64	1/4	1/8
3751	#10-32	3/4	3/16	3/8	3/4	13/64	1/4	1/8
3800	1/4-20	13/16	1/4	7/16	1	17/64	1/4	1/8

Nylon Knurled Finger Nuts

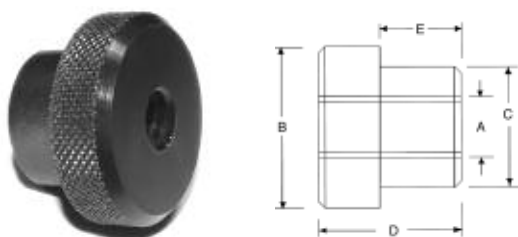

- Machined from Nylatron
- Full internal thread
- Diamond knurl on head
- High strength and rigidity

PART #	A Thread	B	C	D	E
5200	#6-32	1/2	1/4	3/8	1/4
5201	#6-32	3/4	1/4	3/8	1/4
5202	#8-32	1/2	5/16	3/8	1/4
5203	#8-32	1/2	5/16	5/8	1/2
5204	#10-24	1/2	3/8	7/16	1/4
5205	#10-32	1"	3/8	7/16	1/4
5206	1/4-20	3/4	1/2	1/2	1/4
5207	1/4-20	1"	1/2	1"	3/4